

INSTRUCTIONS

FOR TRADE (MANUFACTURING SECTOR) CLIENTS ONLY

PROGRAMMABLE DIGITAL CONTROL UNIT FOR ELECTRIC TOWEL
RAILS

BXGTHAR2A
BXGTHAR2GA
BXGTHART1A
BXGTHART1GA
BXGTHART2PA
BXGTHART2PGA

TABLE ON CONTENTS



Important: These simplified instructions are **only intended to be used by our trade clients (manufacturing- company clients which integrate our OEM components into their systems)**. The purpose of them is to describe the features and the main technical characteristics of the product.

They may under no circumstances be used as the entire list for incorporation, installation and use of the final appliance – this is an internal document which cannot be circulated in its present condition.

It shall be the responsibility of our trade (manufacturing company) clients which design finished products or which integrate our components into their systems to draw up, for use by their customers, instructions for installation and use.

Under all circumstances we recommend that the final draft of the instructions for installation and use, along with the final appliance, be approved by an accredited laboratory, to ensure that the final appliance meets applicable standards.

Drawings and technical information are not contractual and given as indications. They may change depending on product development. Imhotep creation keeps the right to change without notice.

Overview	3
<i>Product plus points</i>	3
Operation	4
<i>Diagram</i>	4
<i>Power ON/Standby mode</i>	4
<i>Selecting the operating mode</i>	4
<i>Boost feature</i>	5
<i>Gauge consumption, energy savings</i>	5
<i>Setting the comfort mode temperature</i>	6
<i>Consumption indication accumulated in kWh, energy savings</i>	6
<i>Child anti-tamper, keypad lock/unlock</i>	6
<i>7 day and daily programme integrated, energy savings</i>	6
<i>Open window detection, energy savings</i>	8
<i>Information about remote control by pilot wire</i>	9
<i>Information about priorities between the different modes</i>	10
<i>Optional: remotely management by infrared remote control</i>	10
User settings	11
<i>Access</i>	11
<i>Backlight setting</i>	11
<i>Setting the Eco mode temperature lowering-level</i>	11
<i>Setting the Frost protection temperature</i>	11
<i>Comfort setpoint temperature limit</i>	12
<i>Setting of the maximum duration of authorised Boost</i>	12
<i>Setting of the maximum ambient temperature for the automatic stop of the Boost</i>	12
<i>Setting the temperature unit</i>	12
<i>Restoring factory settings</i>	13
Installer settings	13
<i>Access</i>	13
<i>Open window detection, activation/ deactivation of the Auto mode</i>	14
<i>PiN code lock</i>	14
<i>Restoring factory settings</i>	15
Expert settings	16
<i>Access</i>	16
<i>Ambient temperature sensor ajustement</i>	16
<i>Setting the power</i>	17
<i>Restoring factory settings</i>	17
Load shedding and power cut	18
<i>Load shedding by pilot wire only</i>	18
<i>Other remotely management by power shutdown</i>	18
<i>In case of power cut, backup</i>	18
Fitting and connections	18
<i>Assembling of the controller on to the towel rails</i>	18
Technical information	19
Product codes	19

OVERVIEW

Range of electronic PID control unit for towel rails, programmable digital control, with pilot wire, white or grey.

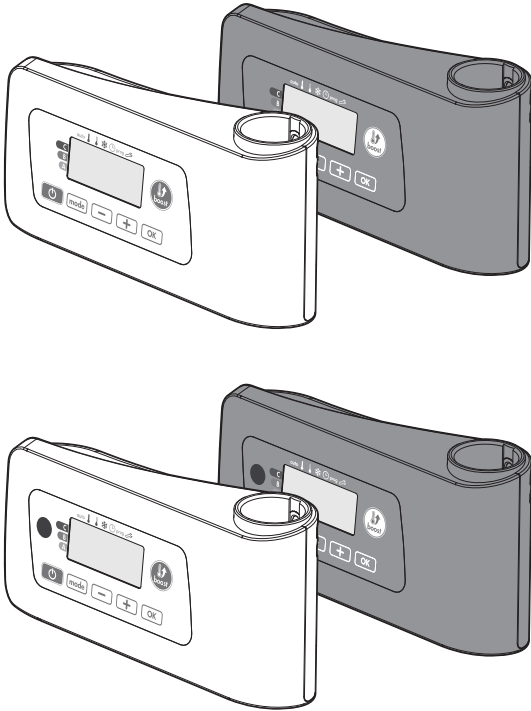

- **Open window detection:** Automatic switching to frost protection mode when the device detect a significant drop in temperature.
- **7 day programme:** you have the option, for each day of the week, of assigning five different program profiles.
- **Child anti-tamper:** The control panel can be locked, making changes impossible.
- **Special safety for social or private rental housing:**
 - Limits of the adjustment range of the Comfort setting temperature.
 - PIN code lock of settings reserved for professionals.
- **A safety feature prevents the room temperature from getting too high** when in Boost mode. Internal protection against heating anomalies
- **Active memory:** Permanent backup of the whole of settings and programming, backup date and time of 3hrs typical.
- **Two positions for output cable** - vertical during transportation, horizontal once it is fitted.
- **Special O-ring supplied** in sachets of 50 in each box.
- An incorporated temperature sensor, which can **not be accessed from the outside** - product is more robust when you are installing it.
- **38mm thick** – this makes packing them with straight-"ladder" towel rails easier.

PRODUCT PLUS POINTS

- Electronic PID control with microprocessor.
- **A safety feature prevents the room temperature from getting too high** when in Boost mode.
- A zero-voltage control device reduces electromagnetic interference **NF performance *** compatible.**
- **Setting temperature can be viewed in all operating modes.**
- **Help for the visually-impaired:** the appliance emits sound beeps which indicate that it is switching from Standby Mode to an active operating mode.
- **Ergonomic to set:** The display is inclined and white back-light (depending on version) to make settings easier to access and view. Setting the module is simple, straightforward and intuitive.
- **Boost:** Adjustable up 90 minutes, increases the speed at which your bathroom heats up and also allows damp clothes and towels to dry quickly.
- **Infrared remote control (optional):** supplied with a wall mount and enables you to remotely control your towel rails.
- **An integrated water-removal system** - very unlikely that water will accumulate inside the control box, even if water gets into it accidentally (meaning increased user safety).
- **Gauge consumption:** Automatic indication of the level of consumption according to the setting temperature.
- **Energy consumption indication:** posting of the estimated amount of energy consumed in kWh since the last reset to 0 of the energy meter.

OPERATION

DIAGRAM

Buttons overview

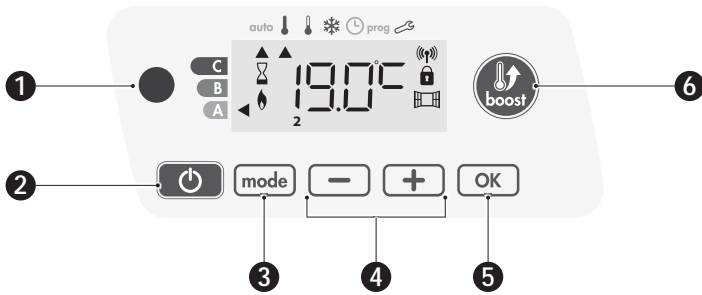

- 1 Infrared receiver
- 2 Button power on/standby mode
- 3 Selecting operating modes
- 4 Plus and minus buttons, used to set temperatures, time, date and 2 programmes
- 5 Save settings
- 6 Boost

Indicators overview

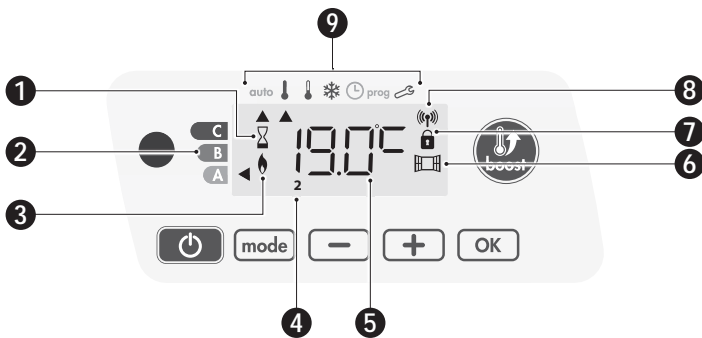

- 1 Boost indicator light
- 2 Gauge consumption
- 3 Heating indicator
- 4 Days of the week (1=Monday ... 7= Sunday)
- 5 Setting temperature
- 6 Open window detection indicator
- 7 Keypad locked
- 8 Radio transmission indicator
- 9 Operation modes:
 - auto** Auto mode
 - ! Comfort mode
 - ! Eco mode
 - * Frost protection mode
 - 🕒 Time and date setting mode
 - prog** Programming mode
 - 🔗 Settings

Important: In Auto, Comfort, Eco and Standby mode, backlight turns off automatically after 20 seconds if no buttons are pressed. It will be necessary to reactivate it by pressing one of the keypad buttons before making settings.



Note

Before carrying out any setting procedures, ensure that the keypad is indeed unlocked (see page 6).

POWER ON/STANDBY MODE

Power on feature

Press the button to put the device in operation, in Auto mode.

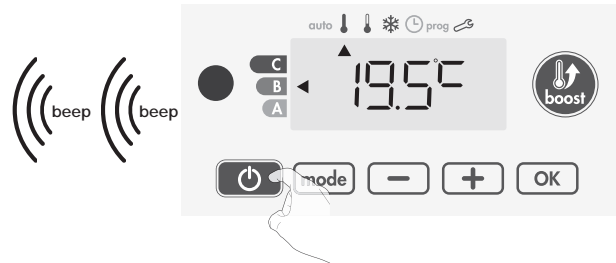

Help for the visually impaired: sound signals

The device makes 2 short beeps to notify that it is in operation, in Auto mode.

Standby mode

This function allows you to stop the heating in summer, for example.

Press the button to put the device in standby mode.

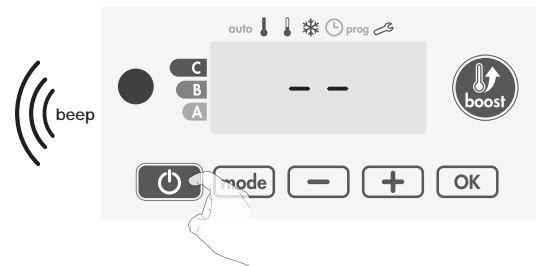

Help for the visually impaired: sound signals

The device makes 1 short beep to notify that it is in standby mode.

SELECTING THE OPERATING MODE

The button allows you to adapt the operating schedule of your device to your needs, depending on the season, whether your home is occupied or not.

Press the button several times to select the required mode.



Mode sequence:

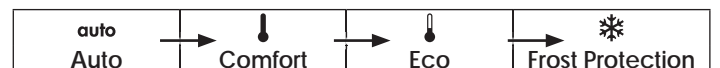

Mode overview

• auto Auto mode

In Automatic Mode, the device will automatically change from Comfort mode to Eco mode according to the established programme.

Display



3 different cases depending on your set-up:

1 7 day and daily programme

Your device has been programmed and is executing Comfort and Eco mode orders in line with the settings and time periods you have selected (see "7 day and daily programme integrated" chapter page 7).

Mode overview

Display

2] Programming by pilot wire

If you do not want to use the programming feature, the device's default setting is non-stop Comfort for 7 days a week, you do not have to change any settings. Orders sent by the pilot wire will only be applied **in Auto mode**, thus your device will automatically receive and apply the programmed orders sent by your power manager or your time switches (see Information about remote control by pilot wire page 9).

3] Without programme

if the 7 day and daily programme is not enabled or no orders are being sent by pilot wire, then your device's factory settings mean that it will operate in nonstop Comfort mode, 7 days of the week.

• Comfort mode

Non-stop Comfort mode. The device will operate 24 hours a day to achieve the temperature which has been set (e.g. 19°C). The Comfort mode temperature level can be set by the user (see Setting the comfort mode temperature page 6).



• Eco mode

Eco, which means the Comfort Mode temperature minus 3.5°C. This enables you to lower the temperature without having to reset the Comfort Mode temperature. Select this mode for shortterm absences (between 2 and 24h) and during the night.



• Frost protection mode

This mode enables you to protect your home against the effects of cold weather (frozen pipes, etc.), by maintaining a minimum temperature of 7°C in it at all times. Select this mode when you will be away from your home for a long time (more than 5 days).



Restoring factory settings See page 13.

BOOST FEATURE



Important: the Boost mode can be enabled at any time, whatever the current operating mode (Auto, Comfort, Eco or Frost protection).

To activate Boost mode, press , the desired temperature setting will be set at maximum for the time period you request. 60 minutes display will flash by default.

- First press = Boost.

During the first minute: the boost symbol and the heating indicator appear and the duration count flash.



During the first minute, you can modify the Boost duration from 0 to the maximal authorised duration of the Boost, such as defined during the user settings (see page 12 for more details) by intervals of 5 minutes (or more quickly by push superior to 2 seconds) by pressing  and . This modification will be saved and effective for the next Boost.

After 1 minute, the Boost count begins and the time is running, minute by minute.

Comment: After 1 minute, you can modify temporarily the duration: it will be valid only for this active Boost and therefore non-recurring.

The Boost can stop for 2 different reasons:

- An order "Stop" has been sent by your energy manager through the pilot wire:

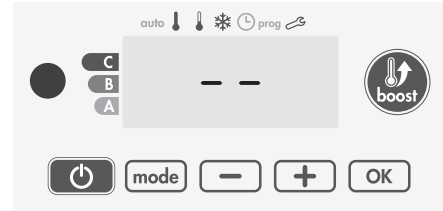

The device stops, -- appears. The cursor moves above auto. When the order Comfort will be sent, the device will be restarted until the count end.

- If the ambient temperature reaches the maximal Boost temperature during the count:



The device switches off but the Boost mode is always active: the count is always displayed, the Boost symbol and the heating indicator flash on the display. When the temperature drops under the maximal authorised temperature, the device will be restarted until the count ends.

- Second press = Boost cancellation.



The cursor moves above the previous active mode and the setting temperature appears.

GAUGE CONSUMPTION, ENERGY SAVINGS

France's Agency for Environment and Energy Management (ADEME) recommends a Comfort setting temperature lower or equal to 19°C.

In the device display, a selector indicates the energy consumption level by positioning it in front of the colour: red, orange or green. So, depending on the setting temperature, you can choose your level of energy usage. As the temperature setting increases, the consumption will be higher.

The gauge appears in Auto, Comfort, Eco and Frost protection modes and whatever the temperature level.

C - Red colour High Temperature level: it is advisable to significantly reduce the setting temperature.	Setting temperature > 22°C When the setting temperature is higher than 22°C	
B - Orange colour Average temperature level: it is advisable to slightly reduce the setting temperature.	19°C < Setting temperature ≤ 22°C When the setting temperature is higher than 19°C and lower or equal to 22°C	

<p>A - Green colour Ideal temperature.</p>	<p>Setting temperature ≤ 19°C When the setting temperature is lower or equal to 19°C</p>	
---	---	---

SETTING THE COMFORT MODE TEMPERATURE

You can access the Comfort temperature set up from the Auto and Comfort Mode. It is preset to 19°C.

Using **-** and **+** you can adjust the temperature from 7°C to 30°C by intervals of 0.5°C.

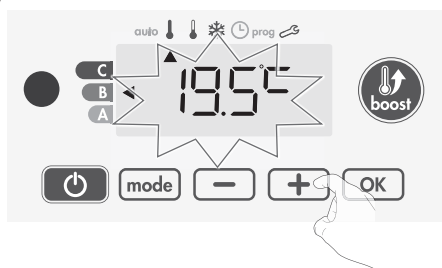

Note: you can limit the Comfort temperature, see page 12 for more details.

CONSUMPTION INDICATION ACCUMULATED IN KWH, ENERGY SAVINGS

It is possible to see the estimation of energy consumption in kWh since the last reset of the energy meter.

• Display of the estimated power consumption

To see this estimation, from Auto, Comfort, Eco or Frost protection mode, then press **OK**.



To exit the display mode of consumption: press **mode** or **OK**, the device is automatically in the previous active mode.

• Resetting the energy meter

To reset the energy meter, from Auto, Comfort, Eco or Frost protection mode, then proceed as follows.

- 1- Press **OK**.
- 2- Press simultaneously **-** and **+** for more than 5 seconds.
To exit resetting the energy meter, press **mode** or **OK**, the device is automatically in the previous active mode.

CHILD ANTI-TAMPER, KEYPAD LOCK/UNLOCK

• Keypad lock

To lock the keypad, press the **-** and **+** buttons and hold them down for 10 seconds. The padlock symbol  appears on the display, the keypad is locked.

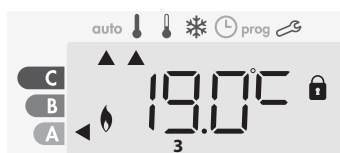

• Keypad unlock

To unlock the keypad, press the **-** and **+** buttons hold them down for 10 seconds again. The padlock symbol  disappears from the display, keypad is unlocked.



When keypad is locked, only the key  is active. If the device is on Standby mode when the keypad is locked, you have to unlock it for the next heating on to access the setup.

7 DAY AND DAILY PROGRAMME INTEGRATED, ENERGY SAVINGS

In this mode, you have the option of programming your device, by setting one of the five programmes on offer for each day of the week.

• Access to the programming mode

From Auto, Comfort, Eco or Frost protection mode, press **mode** for 5 seconds to enter into the programming mode.

Schematic sequence of programming settings:



• Setting day and time

In this mode, you can set day and time to program your device in line with your needs.

- 1- From Auto, Comfort, Eco or Frost protection mode, press **mode** for 5 seconds.
The cursor moves to the setting day and time mode.

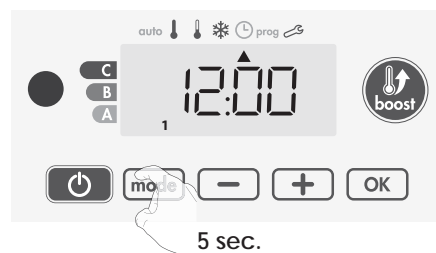

- 2- Select using **-** or **+**. The two hour figures will flash. The hours will scroll quickly, if you press the **-** or **+** and hold them. Save by pressing **OK**.

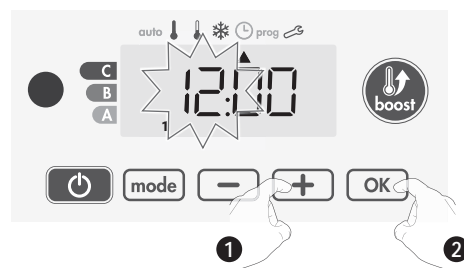

- 3- The two minute figures will flash. Select using **-** or **+**. Save by pressing **OK**.

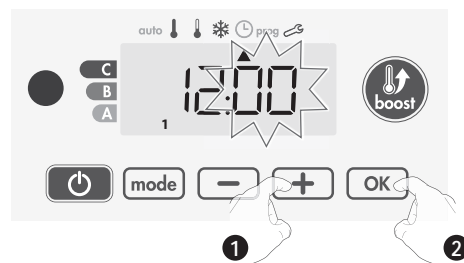

- 4- The cursor above the number 1 (which represents the Monday) will flash. Select the date using **-** or **+**. Save by pressing **OK**.

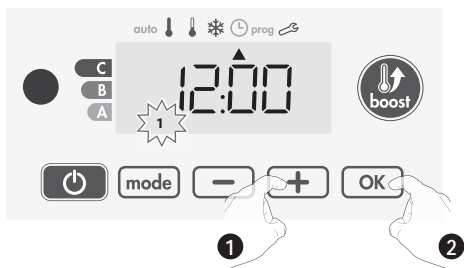

- 5- To change and/or allocate programmes press **mode**. To exit the setting the time and day mode, press **mode** 3 times.

• Choices programmes

Schematic sequence of programmes:

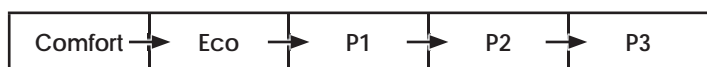

Your device's default setting is non-stop Comfort for 7 days a week.

• Programmes overview

- **Comfort:** your device will operate in Comfort mode, 24 hours a day, as regards each day selected.

Note: You can set the Comfort mode temperature to the temperature you require (see Setting the comfort mode temperature page 6).

- **Eco:** The device will operate 24 hours a day in Eco mode.

Note: You can set the temperature-lowering parameters (see Setting the Eco mode temperature lowering-level page 11).

- **P1:** your device will operate in Comfort mode from 06:00 to 22:00 (and in Eco mode from 22:00 to 06:00).

- **P2:** your device will operate in Comfort mode from 06:00 to 09:00 and from 16:00 to 22:00 (and in Eco mode from 09:00 to 16:00 and from 22:00 to 06:00).

- **P3:** your device will operate in Comfort mode from 06:00 to 08:00, from 12:00 to 14:00 and from 18:00 to 23:00 (and in Eco mode from 23:00 to 06:00, from 08:00 to 12:00 and from 14:00 to 18:00).

• Potential modifications of programmes

If the default time schedules for the P1, P2 and P3 programmes does not suit your routines, you can change them.

Modifying the P1, P2 or P3 programmes.

If you modify the time schedules for the P1, P2 or P3 programmes, the schedules will be modified for all the days of the week for which P1, P2 or P3 had been set.

- 1- If you just set the time and day, go to step 2.

From Auto, Comfort, Eco or Frost protection mode, press **mode** for 5 seconds.

When the cursor moves above the setting time symbol ⌚, press **mode** shortly.

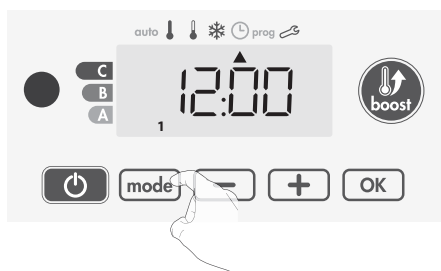

- 2- Press **-** or **+**. The cursor moves above **prog**.

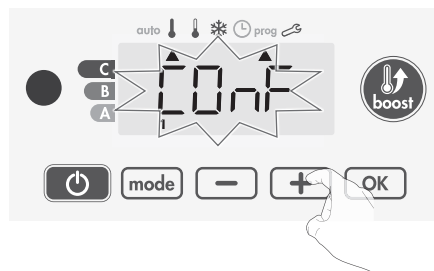

- 3- With **-** or **+**, select P1. P1 will flash. Press **OK** for 5 seconds to make changes.

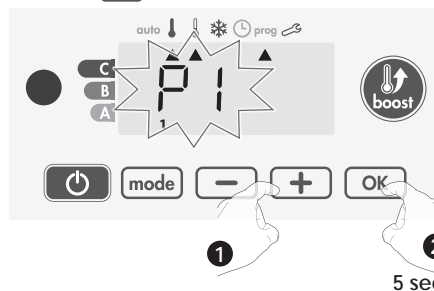

- 4- The P1 start time (which by default is 06:00) will flash.

Using **-** or **+**, you can change this time, by increments of 30 minutes.

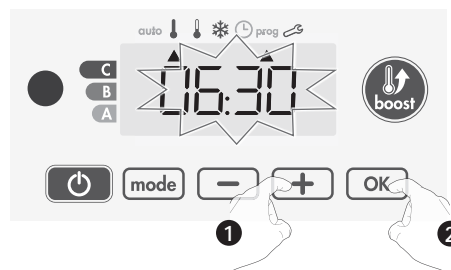

Save by pressing **OK**.

- 5- The P1 end time (which by default is 22:00) will flash. Using **-** or **+**, you can change this time, by increments of 30 minutes.

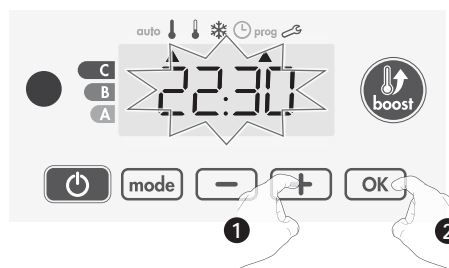

Save by pressing **OK**.

- 6- Press **mode** to exit the programming Mode and return to Auto Mode.

Note: without action on the keys, it will return to Auto after a few minutes.

● Choices and allocation programmes

- 1- If you just set the time and day, the cursor moves automatically under **PROG**.

From Auto, Comfort, Eco or Frost protection mode, then press **[mode]** for 5 seconds. When the cursor positioned under the set time symbol ⌚, press **[mode]** again.

Prior information:
display area



Correspondence days / numbers	
Monday	1
Tuesday	2
Wednesday	3
Thursday	4
Friday	5
Saturday	6
Sunday	7

The days of the week will scroll on display with the programmes that you set for them, meaning Comfort **CONF** every day.

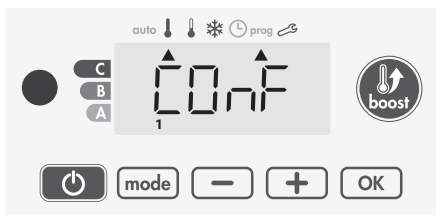

- 2- Press **[-]** or **[+]**.

The programme set for day 1 (1= Monday, 2 = Tuesday, etc.) will flash.

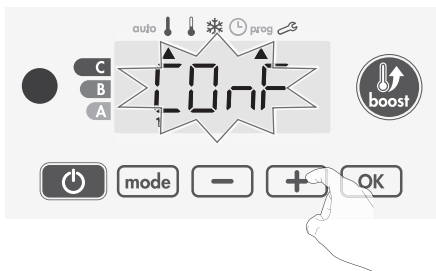

- 3- Chose the programme you want for this day with **[-]** or **[+]**.

Save by pressing **[OK]**.

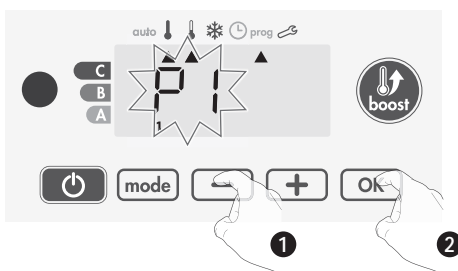

- 4- The programme assigned to the second day of the week (Tuesday) will flash.

Repeat the procedure described previously (in point 3) for each day of the week.

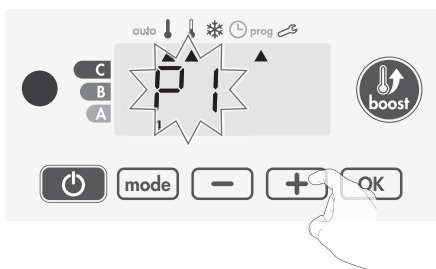

- 5- Once you have chosen a programme for each day, confirm your selection by pressing **[OK]**. The days of the week will successively scroll on display with the programmes that you set for them (P1, P2, P3, CONF or ECO).

To exit the Programming mode, press **[mode]** twice.

● Viewing the programmes that you have selected

- From Auto, Comfort, Eco or Frost protection mode, press **[mode]** for 5 seconds. Press **[mode]** twice, the programme for each day of the week (Comfort, Eco, P1, P2 or P3) will scroll on display in front of you.

- To exit the programme viewing mode, press **[mode]** twice.

● Manual and temporary exemption from a running programme

This function allows you to change the setting temperature temporarily until the next scheduled change in temperature or the transition to 0:00.

Example:

- 1- The device is in Auto mode, the running programme is Eco 15,5°C.

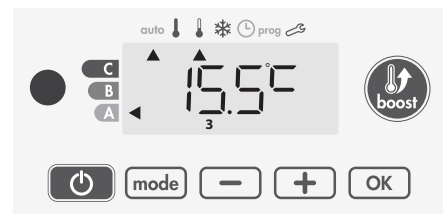

- 2- By pressing **[-]** or **[+]**, you can change temporarily the desired temperature up to 18°C for example.

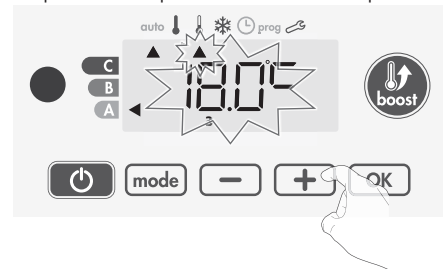

Note: The cursor corresponding to the operating mode, i.e Eco mode in our example, is blinking during the duration of the temporary derogation.

- 3- This change will be automatically cancelled at the next change of programme or transition to 0:00.

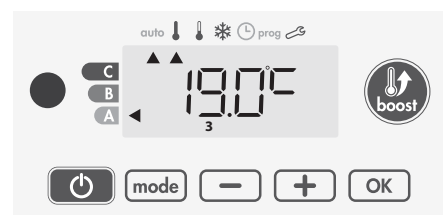

OPEN WINDOW DETECTION, ENERGY SAVINGS

● Important information about the open window detection

Important: the open window detection is sensitive to temperature variations. The device will react to the window openings in accordance with different parameters: temperature setting, rise and fall of temperature in the room, outside temperature, location of the device...

If the device is located close to a front door, the detection may be disturbed by the air caused by opening door. If this is a problem, we recommend that you disable the automatic mode

open window detection (see page 14). You can, however, use the manual activation (see below).

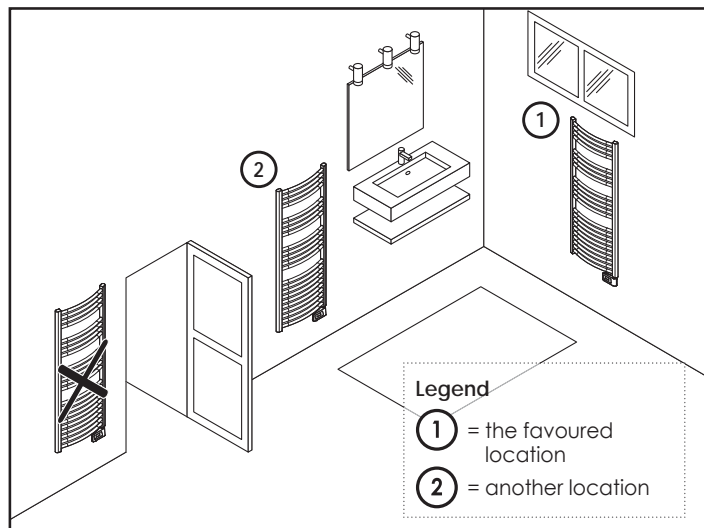

• Overview

Lowering temperature cycle by setting frost protection during ventilation of a room by opened window. You can access the open window detection from the Comfort, Eco and Auto modes. Two ways to enable the detector:

- **Automatic activation**, the lowering temperature cycle starts as soon as the device detects a temperature change.
- **Manual activation**, the cycle of lowering temperature starts by pressing a button.

• Automatic activation (factory settings)

To disable this mode, see page 14. The device detects a temperature fall. An opened window, a door to the outside, can cause this temperature fall.

Note: The difference between the air from the inside and the outside must cause a significant temperature fall to be perceptible by the device.

This temperature drop detection triggers the change to Frost Protection mode.

• Manual activation

By pressing for more than 5 seconds, the device will switch on Frost protection mode.

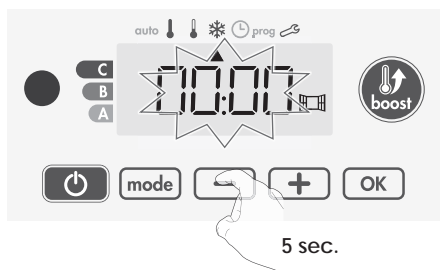

• Frost protection digital meter

When the device performs a lower temperature cycle due to opened window, a meter appears on the display to show the cycle time. The counter is automatically reset at the next time to Frost protection by opened window (automatic or manual activation).

• Stop the Frost protection mode

By pressing one button, you stop the Frost protection mode.

Note: if a temperature rise is detected, the device may return to the previous mode (active mode before the open window detection).

INFORMATION ABOUT REMOTE CONTROL BY PILOT WIRE

• Overview

Your device can be controlled by a central control unit through a pilot wire, in which case the different operating modes will be remotely enabled by the programmer.

You can only control the device by pilot wire in the Auto mode. In the other modes, the orders transmitted by the pilot wire will not be executed.

In general, a pilot wire control system makes it possible to impose externally a lowering of the temperature setpoint, combined with the internal programming.

If several lowering requests appear simultaneously, priority is given to the lowest temperature setpoint, thus maximizing savings (see information on priorities for different modes on page 10). When a signal is sent from the pilot wire, the self learning optimization function is suspended.

Below the different views of the display for each order sent by pilot wire:

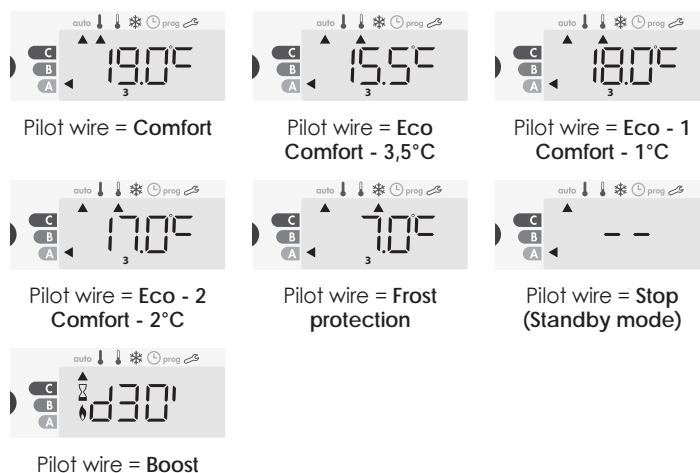

• Exemption to an order coming from a pilot wire external programmer

This feature allows you to modify temporarily the setting temperature until the next order sent by the central control unit or the transition to 00:00.

Example:

- 1- The device is in Auto mode. The central control unit sent an Eco order 15,5°C.

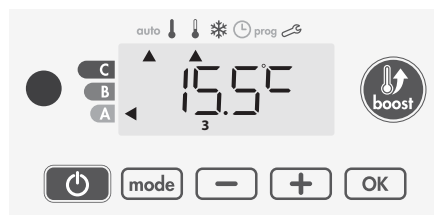

- 2- By pressing or , you can change temporarily the desired temperature up to 18°C for example.

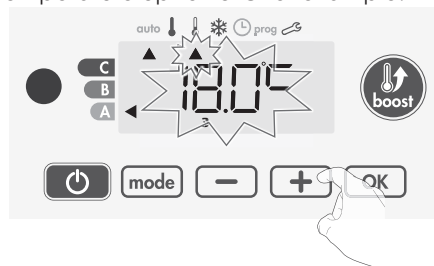

Note: The cursor corresponding to the operating mode, i.e Eco mode in our example, is blinking during the duration of the temporary derogation.

3- This modification will be automatically cancelled at the next order sent by the central control unit or the transition to 00:00.

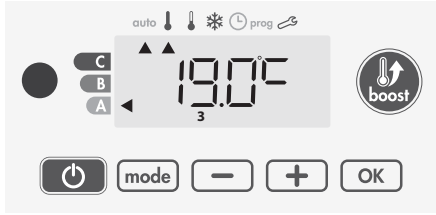

INFORMATION ABOUT PRIORITIES BETWEEN THE DIFFERENT MODES

• Principe

In **Comfort, Eco and Frost protection modes**, only orders of the open window sensor will be considered.

In **Auto mode**, the device can receive different orders coming from :

- 7 day and daily programming integrated (Comfort or Eco orders);
- 6-order pilot wire, if connected to central control unit;
- Open window detector.

In general, it is the lowest received order which prevails except when the pilot wire is connected to an energy management system, in this case the orders of the pilot wire take priority.

- If an open window is detecting, switching to frost protection takes precedence unless a load shedding order is present on the pilot wire.
- The Boost activation will take precedence over others orders received except when the standby (stop) order is present on the pilot wire, the device will switch off and the Boost will be not activated.

• Examples

- + 7 day and daily programming = Comfort
- + Pilot wire 6 orders = Eco

= Eco

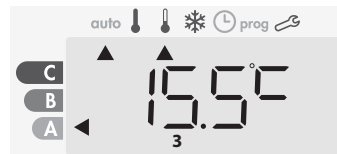

- + 7 day and daily programming = Eco
- + Pilot wire 6 orders = Stop (standby mode)
- + Open window detector = Frost protection

= Standby mode



OPTIONAL: REMOTELY MANAGEMENT BY INFRARED REMOTE CONTROL

Your towel rails can be managed by a remote control with infrared transmission through its IR receiver located on the front of the controller.

• Diagram

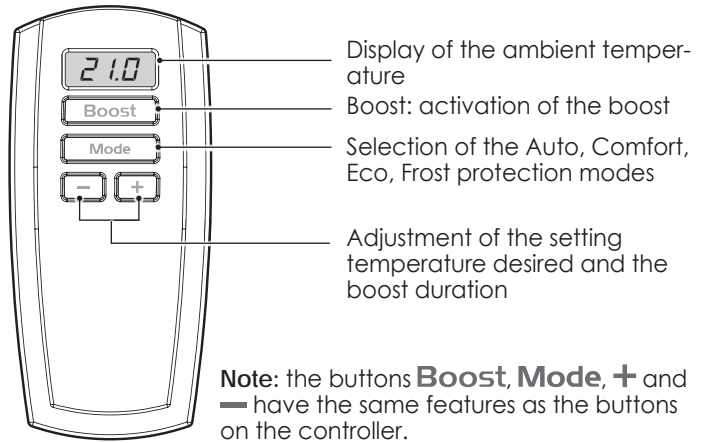

• Operation

Position the remote control toward the infrared receiving window of the device.

Check that there is no obstacle between the remote control and the infrared receiver to disturb the transmission.

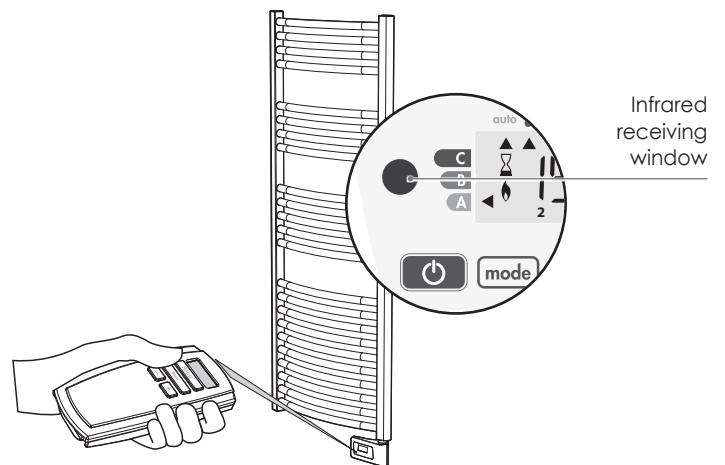

USER SETTINGS

ACCESS

You access to user settings in 3 steps:
From Auto, Comfort, Eco or Frost protection mode :

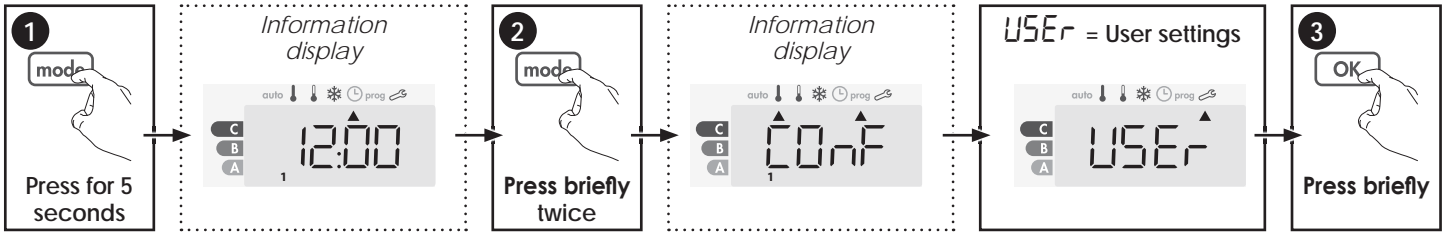

Setting sequence:

Backlighting → Eco mode temperature lowering-level → Frost protection temperature → Comfort setting temperature limit → Maximal Boost duration → Maximum ambient temperature → Temperature unit

BACKLIGHT SETTING

1- Three modes can be set:

- L1 = Temporary backlighting: Backlight of the display when a button is pressed.
- L2 = Non-stop backlighting: Backlight of the display all the time.
- L3 = In this version, the device will work according to the L1 mode.

L3 mode is the default setting.

Press **-** or **+** to choose the setting you require.

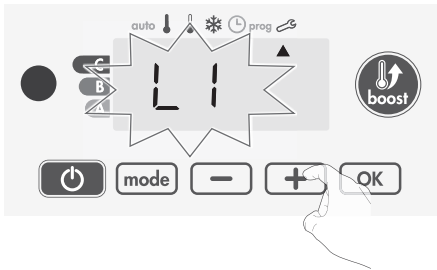

2- Press **OK** to save and move to the next setting.

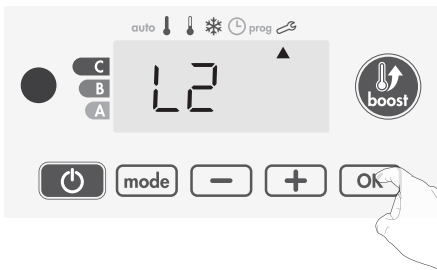

To exit the user settings, press **mode** twice.

SETTING THE ECO MODE TEMPERATURE LOWERING-LEVEL

The drop in temperature is set at -3.5°C compared to the set temperature of the Comfort mode. You can adjust the lowered level from -1°C to -8°C, by intervals of 0.5°C.

Important: whatever the lowering level set, the Eco setting temperature will never exceed 19°C.

3- Press **-** or **+** to obtain the temperature level you require.

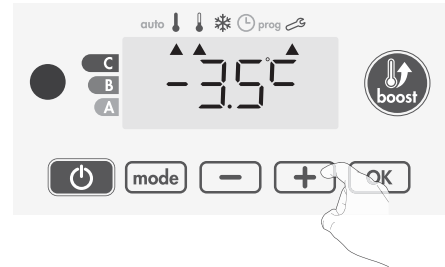

4- Press **OK** to save and move to the next setting.

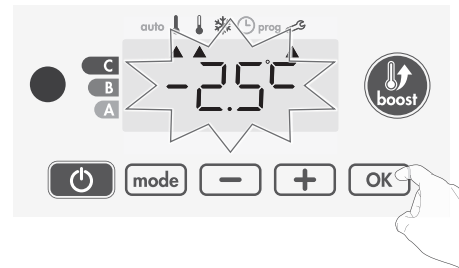

To exit the user settings, press **mode** twice.

SETTING THE FROST PROTECTION TEMPERATURE

Your device is preset at 7°C. You can adjust the Frost protection temperature from 5°C to 15°C, by intervals of 0.5°C.

5- Press **-** or **+** to obtain the temperature you require.

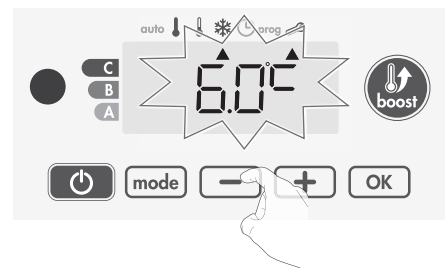

6- Press **OK** to save and move to the next setting.
To exit the user settings, press **mode** twice.

COMFORT SETPOINT TEMPERATURE LIMIT

You can limit the setting temperature range by introducing a maximum and / or minimum setting, preventing unintentional changes in temperature.

• Low temperature limit

Locking of the setting range using a minimum temperature stop, preventing the temperature from being set below that temperature.

The minimum setting is preset to 7°C. You can adjust from 7°C to 15°C by intervals of 1°C.

7- To change the minimum temperature setting, press **-** or **+** then save by pressing **OK**.

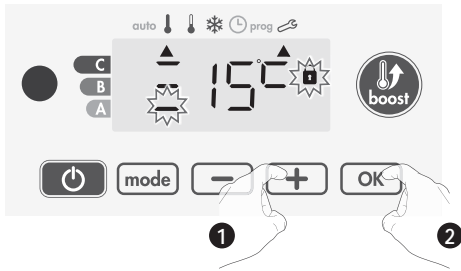

If you do not want to change it, press **OK**: the device changes automatically to set the maximum setting. To exit the user settings, press **mode** twice.

• High temperature limit

Locking of the setting range using a maximum temperature increase, preventing the temperature from being set above that temperature.

The maximum setting is preset to 30°C. You can adjust from 19°C to 30°C by intervals of 1°C.

8- To change the maximum temperature setting, press **-** or **+**.

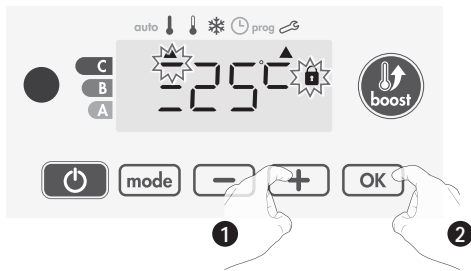

To save and move automatically to the next setting, press **OK**. To exit the user settings, press **mode** twice.

SETTING OF THE MAXIMUM DURATION OF AUTHORISED BOOST

The maximum duration of Boost is preset at 60 minutes. You can adjust it from 30 to 90 minutes by intervals of 30 minutes.

9- The Boost symbol and the heating indicator appears on the display and the preset duration of 60 minutes flash.



10- Press **-** or **+** to display the desired duration.

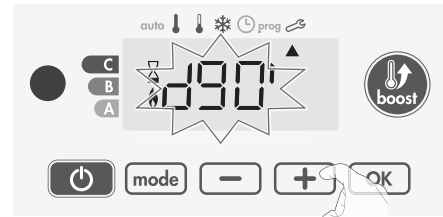

11- To save and move automatically to the next setting, press **OK**.

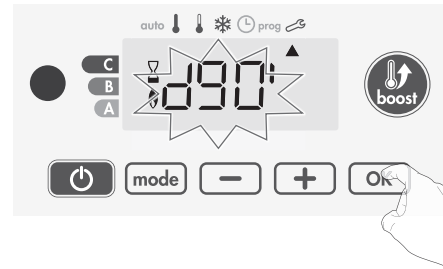

To exit the user settings, press **mode** twice.

SETTING OF THE MAXIMUM AMBIENT TEMPERATURE FOR THE AUTOMATIC STOP OF THE BOOST

When the Boost is enabled, the device has to heat the room until the temperature limit: the maximum ambient temperature. When it is reached, the Boost stops automatically. It is preset at 35°C, you can adjust it from 25°C to 39°C by intervals of 1°C.

The Boost symbol and the heating indicator appear on the display and the maximum temperature flashes.

12- You can set the Boost maximum temperature by pressing **-** or **+** from 25°C to 39°C by intervals of 1°C.

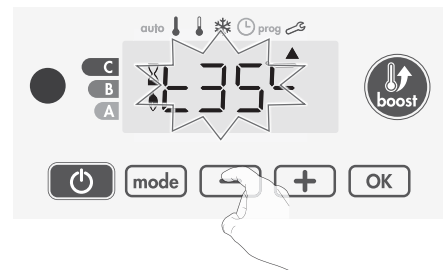

13- To save and move automatically to the next setting, press **OK**. To exit the user settings, press **mode** twice.

SETTING THE TEMPERATURE UNIT

The pre-set temperature unit is degrees Celsius. This setting cannot be changed on this version.

14- To move automatically to the next setting, press **OK**. To exit the user settings, press **mode** twice.

RESTORING FACTORY SETTINGS

In order to a coming back to factory settings, proceed in the following order:

- 1- From the setting of the temperature unit, press **OK**. *rEST* appears on the display.

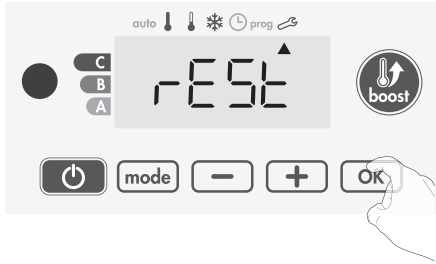

- 2- NO appears. Press **-** or **+** to select YES.

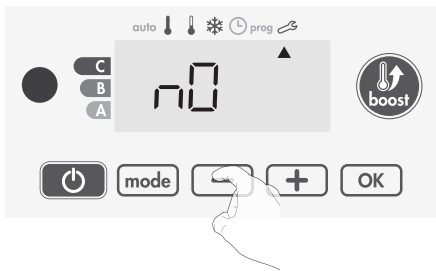

YES = Factory settings reset
nO = Factory settings not reset

- 3- Press the key **OK** for 5 seconds. The device returns to its initial configuration and goes back automatically to the home display of the user settings.

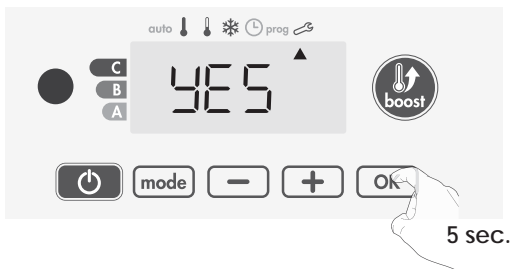

The following factory values will be effective:

Parameters	Factory settings
Operating	
Comfort setting temperature	19°C
Boost duration	60 min.
Keypad lock	Disabled
User settings	
Backlighting	L3
Eco mode temperature lowering-level	-3,5°C
Frost protection temperature	7°C
Minimum set of Comfort setting temperature	7°C
Maximum set of Comfort setting temperature	30°C
Maximal Boost duration	60 min.
Maximum ambient temperature for the automatic stop of the Boost	35°C
Temperature unit	°C

Press **mode** to exit the user settings.

INSTALLER SETTINGS

ACCESS

You access to installer settings in 4 steps:
 From Auto, Comfort, Eco or Frost protection mode :

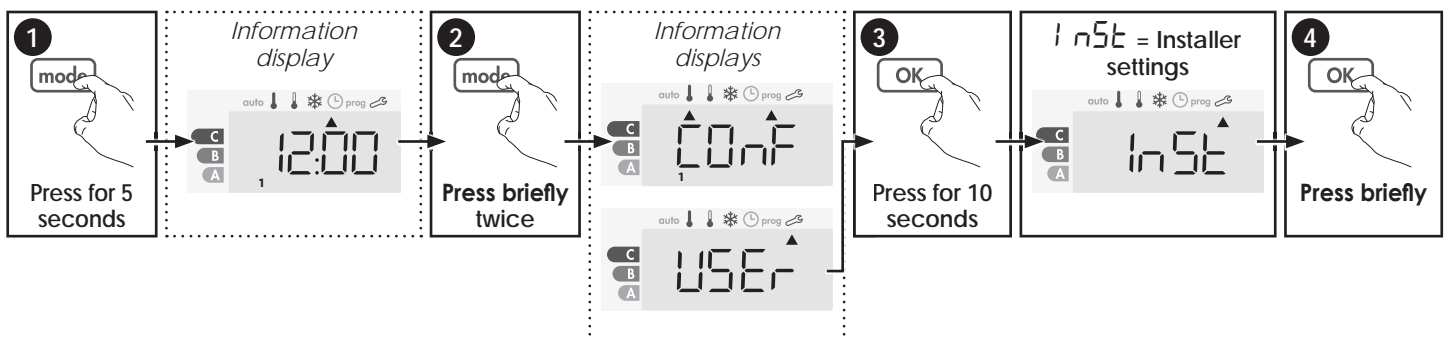

Setting sequence:

Open window detection → PiN code lock → Restoring factory settings

OPEN WINDOW DETECTION, ACTIVATION/ DEACTIVATION OF THE AUTO MODE

The automatic mode enabled is the default setting.

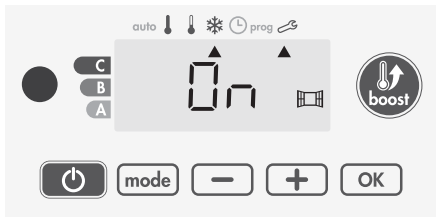

1- Press **-** or **+**.

On = automatic mode enabled.

OFF = automatic mode disabled.

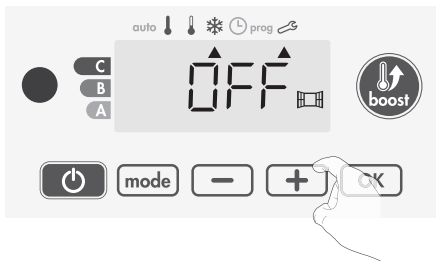

2- To save and move automatically to the next setting, press **OK**. To exit the user settings, press **mode** 3 times.

1- By default registered PIN code is 0000.
Press **-** or **+** to select 0. It is blinking. Save by pressing **OK**.

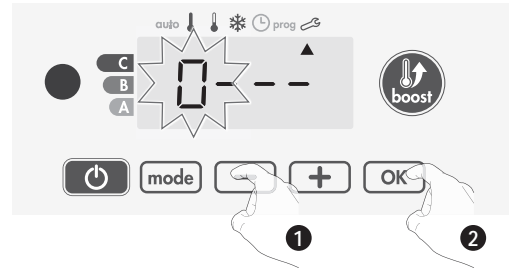

2- For others numbers, select 0 by press **OK**.

When 0000 appears, press on **OK** again to save and exit.

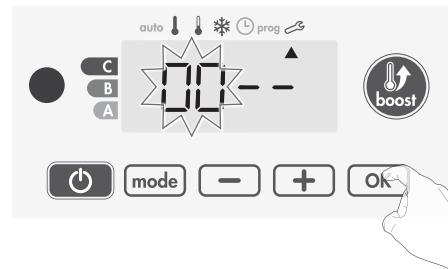

The PIN code is initialized, the next setting automatically appears: PIN Code activation.

● Activation/deactivation of the PIN Code

1- **OFF** appears on the display.

Press **-** or **+** to enable PIN code.

On appears on the display.

On = PIN code enabled

OFF = PIN code disabled

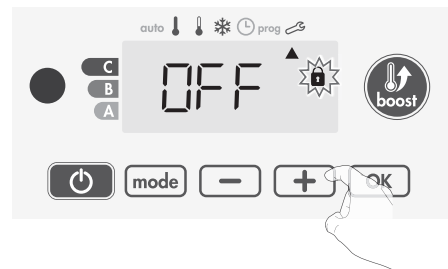

2- Press **OK** to save and return to the home installer settings display.

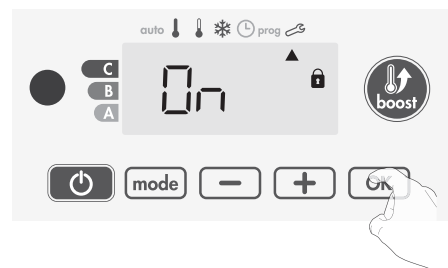

The PIN code is enabled. Any modification of reserved settings listed in "Overview" is now impossible.

PIN CODE LOCK

● Overview

Your heating device is protected by a safety code against nonauthorised use. The PIN code (Personal Identity Number) is a customisable 4 numbers code. When enabled, it prevents access to the following settings:

- Selecting the Comfort mode : The access to the Comfort mode is forbidden, only the Auto, Eco and Frost protection modes are available.
- Minimum and maximum Limits of the setting temperature range (the Comfort temperature modification is forbidden out of the authorised setting range).
- Programming mode.
- Open window detection settings.
- Setting the Eco mode temperature lowering-level.
- Setting the Frost protection temperature.

3 important steps are needed for the first use of the PIN code lock:

- 1 - **PIN code initialisation**, enter the preset PIN code (0000) to access to the feature.
- 2 - **Activation of the PIN Code** to lock settings which will be protected by the PIN code.
- 3 - **Customizing the PIN code**, replace 0000 by the customized code

● PIN code initialisation

By default, the PIN code is not enabled. **OFF** appears on the display.

● Customizing the PIN code

If you have just activated the PIN code, follow the stages described below.

Alternatively, you must copy the steps 1 and 2 of the initialisation process as well as the steps 1 and 2 of the activation process before personalising the PIN code.

Please remember that the personalisation of the PIN code can only be set once the initialisation and activation of the PIN code has been completed.

1- When **0n** appears, press **OK** for at least 5 seconds.

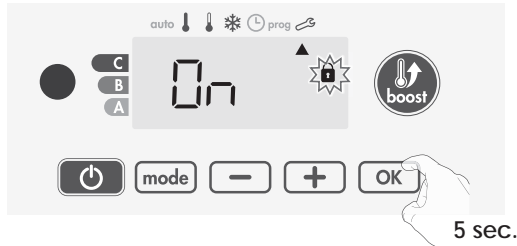

2- The 0000 code appears and the first number blinks. Press **-** or **+** to select the first desired number then press **OK** to save and exit. Repeat this operation for remaining 3 numbers.

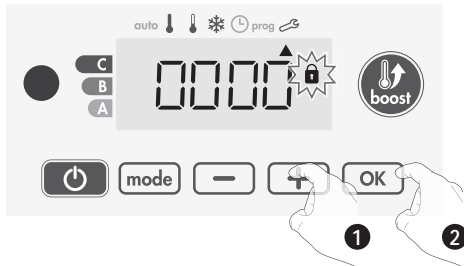

3- Press **OK** to confirm. The new code is now saved.



4- Press again on **OK** to exit setting PIN code mode and go back to the home display of the installer settings.



To exit the Installer settings, press **mode** twice.

2- **n0** appears. Press **-** or **+** to select **YES**.

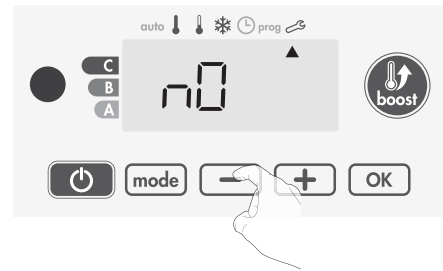

YES = Factory settings reset
n0 = Factory settings not reset

3- Press the key **OK** for 5 seconds. The device returns to its initial configuration and goes back automatically to the home display of the installer settings.

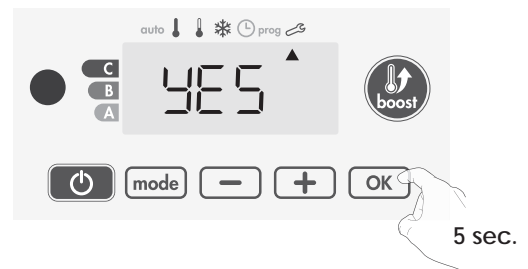

The following factory values will be effective:

Settings	Factory settings
Operating	
Comfort setting temperature	19°C
Boost duration	60 min.
Keypad lock	Disabled
User settings	
Backlighting	L3
Eco mode temperature lowering-level	-3,5°C
Frost protection temperature	7°C
Minimum set of Comfort setting temperature	7°C
Maximum set of Comfort setting temperature	30°C
Maximal Boost duration	60 min.
Maximum ambient temperature for the automatic stop of the Boost	35°C
Temperature unit	°C
Installer settings	
Automatic open window detection	Enabled
PIN code protection	Disabled
Value of the PIN code	0000

To exit the installer settings, press **mode** twice.

RESTORING FACTORY SETTINGS

If the PIN code protection is disabled, the user and installer settings are re-initialized:

1- From the PIN code setting, press **OK**. **rEST** appears briefly on the display.

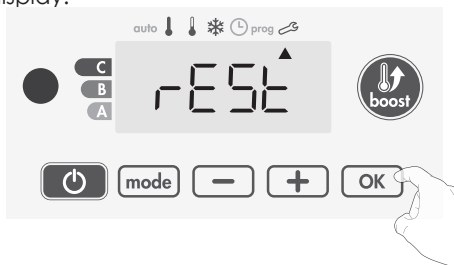

EXPERT SETTINGS

ACCESS

You access to expert settings in 5 steps.
From Auto, Comfort, Eco or Frost protection mode :

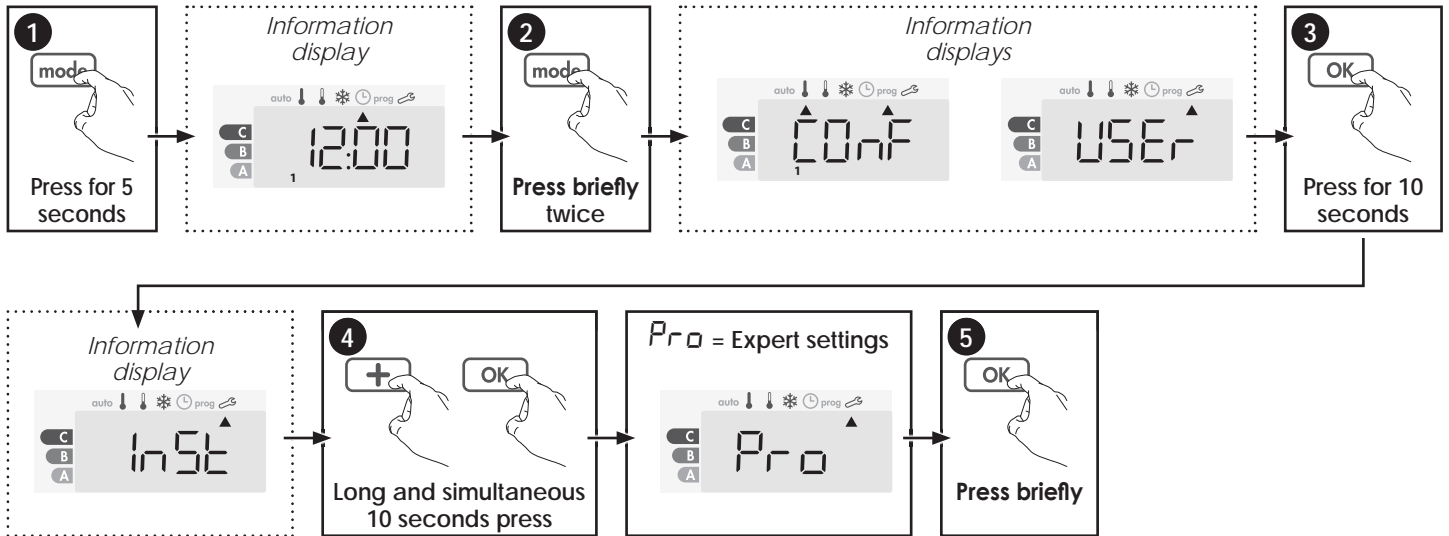

Setting sequence:

Ambient temperature sensor adjustment → Setting the power → Restoring factory settings

AMBIENT TEMPERATURE SENSOR ADJUSTEMENT

● Overview

Important: This operation is reserved for professional installers only; any wrong changes would result in control anomalies.

In which case if the temperature measured (measured by reliable thermometer) is different by at least 1°C or 2°C compared to the setting temperature of the radiator.

The calibration adjusts the temperature measured by the ambient temperature sensor to compensate for a deviation from +5°C to -5°C by intervals of 0.1°C.

● Ambient temperature sensor adjustment

1- If the room temperature difference is negative, example :

Setting temperature (what you want) = 20°C.
Ambient temperature (what you read on a reliable thermometer) = 18°C.
Difference measured = -2°C.

Important: Before carrying out the calibration it is recommended to wait for 4h after the setting temperature modification to insure that the ambient temperature is stabilized.

To correct, then proceed as follows :

Sensor temperature = 24°C

(The measured temperature may be different due to the location of the thermostat in the room).



Decrease the temperature measured by the ambient temperature sensor by 2°C by pressing [-].

In our example the measured temperature by the sensor goes from 24°C to 22°C.

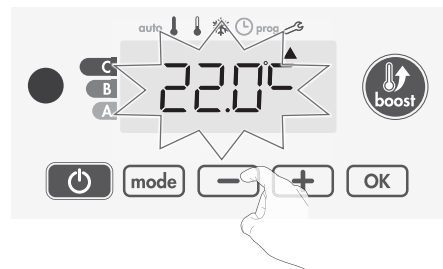

2- If the room temperature difference is positive, example :

Setting temperature (what you want) = 19°C.
Ambient temperature (what you read on a reliable thermometer) = 21°C.
Difference measured = +2 °C.

To correct, then proceed as follows :

Sensor temperature = 21°C.

(The measured temperature may be different due to the location of the thermostat in the room).



Increase the temperature measured by the ambient temperature sensor by 2°C by pressing **+**.

In our example the measured temperature by the sensor goes from 21°C to 23°C.

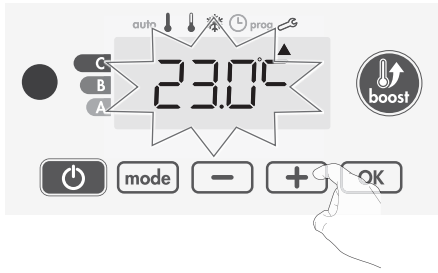

To validate, save the new value and exit the mode, press **OK**. To exit the Expert settings, press **mode** 3 times.

• The reset to zero of the sensor calibration

To put the value of the correction to "0", do the following :

- 1- When the temperature measured by the sensor appears, press **-** or **+** for at least 3 seconds.



- 2- To save and move automatically to the next setting press **OK**. To exit the Expert settings, press **mode** 3 times.

Important: These changes should be performed by a qualified staff, it should be performed in production or on site during the first installation

SETTING THE POWER

To have a controller adapted to the towel rails and estimate the energy consumed, it is essential to set the power of the device.

- 1- Pre set value: 500W. Select a value between 500W and 1500W by pressing **-** or **+**.

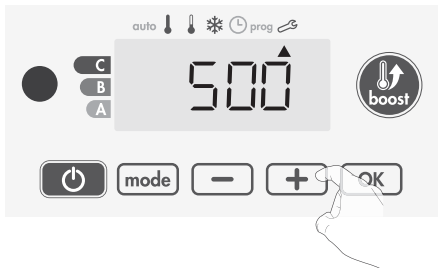

- 2- To save and move automatically to the next setting press **OK**.



- 3- To save the Expert settings, press **mode** 3 times.

RESTORING FACTORY SETTINGS

If the PIN code protection is disabled, the user, installer and expert settings are re-initialized:

- 1- From the Power setting setting, press **OK**. **REST** appears on the display.

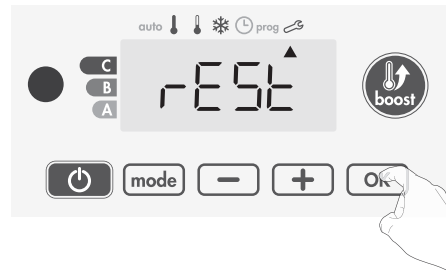

- 2- **n0** appears. Press **-** or **+** to select **YES**.

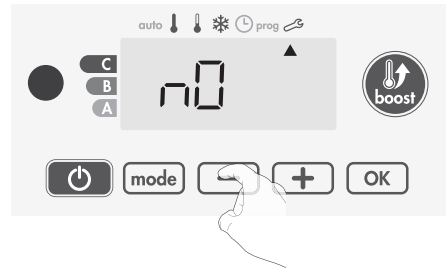

YES = Factory settings reset
n0 = Factory settings not reset

- 3- Press the key **OK** for 5 seconds. The device returns to its initial configuration and goes back automatically to the Auto mode.



The following factory values will be effective:

Settings	Factory settings
Operating	
Comfort setting temperature	19°C
Boost duration	60 min.
Keypad lock	Disabled
User settings	
Backlighting	L3
Eco mode temperature lowering-level	-3,5°C
Frost protection temperature	7°C
Minimum set of Comfort setting temperature	7°C
Maximum set of Comfort setting temperature	30°C
Maximal Boost duration	60 min.
Maximum ambient temperature for the automatic stop of the Boost	35°C
Temperature unit	°C

Settings	Factory settings
Installer settings	
Automatic open window detection	Enabled
PIN code protection	Disabled
Value of the PIN code	0000
Experts settings	
Power	500W

To exit the Expert settings, press **mode** 3 times.

LOAD SHEDDING AND POWER CUT

LOAD SHEDDING BY PILOT WIRE ONLY

In case of over consumption, an energy power manager or a disconnecter doesn't trigger a trip of the general (example: simultaneous operating of your various household appliances and others).

This allows you to reduce the energy power subscribed and therefore optimize your subscription with your energy provider.

IMHOTEPE controllers are designed to operate with **load shedding systems with pilot wire only**.

Orders sent by the pilot wire are executed by the device's electronic controller which will apply setpoint corresponding to the order sent.

The « Stop » order corresponds to the load shedding. When this order is received, the device switches to "standby" and then returns to the initial operating mode.

OTHER REMOTELY MANAGEMENT BY POWER SHUTDOWN



Important : The power supply of the device should be cut when working on the electrical system only. The load shedding does not be operated by an additional system with mechanized power shutdown (with contactor...). Unlike pilot wire shedding, the load shedding with frequent mechanized power shutdowns can cause deterioration of the device depending of the quality of switching elements used. This type of deterioration would not be covered by the manufacturer's warranty.

If remotely stop or standby orders should be frequently operated, you must use the pilot wire (refer to previous "Load shedding by pilot wire only" subsection).

IN CASE OF POWER CUT, BACKUP

- **After short power cuts (less than 3 hrs)**, the device will start up again without any outside input being required – you do not have to do anything. All the settings and the correct time will be saved.

When the main power supply returns, your device will again operate using correct time and the settings that were programmed before the power cut (as regards desired temperature, operating mode, programmes, etc.). It will start up again in the mode which was active before the power outage

- **For longer power supply cuts (more than 3 hrs)**, check the timer setting. All the other settings are automatically and permanently saved.

FITTING AND CONNECTIONS

ASSEMBLING OF THE CONTROLLER ON TO THE TOWEL RAILS

Important:

Before carrying out any connection tasks, cut off the power supply to the electronic regulator using the circuit breaker or the protection fuse in the power supply circuit



Connection tasks must be carried out by a **qualified professional installer**.

• Assembling of the controller on to the towel rails

1- Fitting the joint to the cartridge heater (the cartridge)

Fit the joint (supplied) onto the cartridge heater to ensure that the latter fits snugly into the electronic regulator:

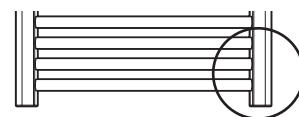

Bottom of the towel rails

Another o-ring, may be present on the cartridge at this location, depending on the manufacturer. It will in no way hinder assembly of the product. Leave it in place. However, despite the presence of o-ring you still have to put o-ring(supplied) in place.

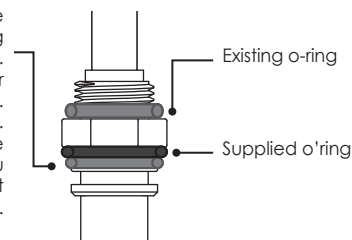

2- Connecting the electronic regulator to the cartridge heater

Bring the electronic regulator close to the cartridge heater, in order to connect the two insulated female Faston lugs (the output contacts) to the two male lugs on the cartridge. Press the lugs together firmly.

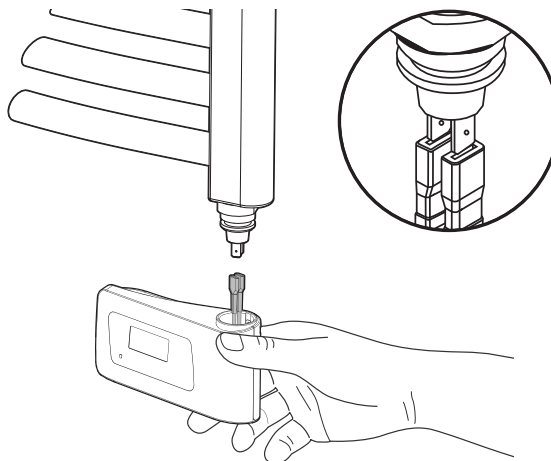

3- Fitting the electronic regulator to the cartridge heater

Fit the regulator to the base of the cartridge heater.

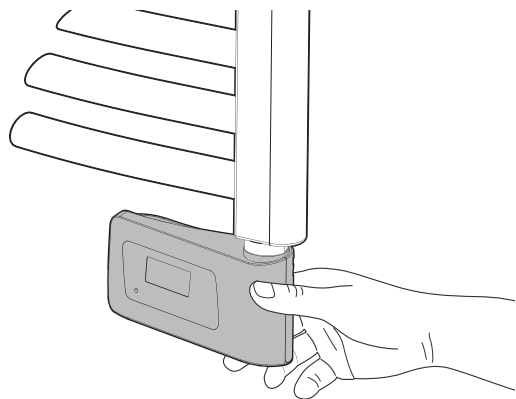

4- Fitting and tightening the electronic regulator onto the cartridge heater.

Keep the electronic regulator (B) pressed onto the base by exerting an upwards force (and thus ensuring that joint is compressed (C) when you are screwing in the cone-point set screw to the back of the product using an allen key (A).

Tightening torque required: 0,5N.m

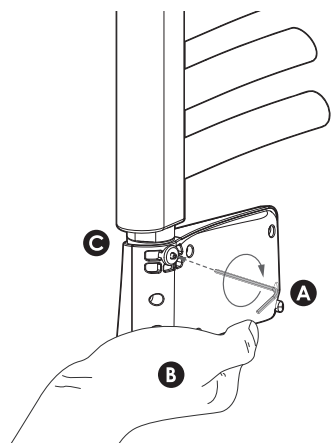

TECHNICAL INFORMATION

General specifications:

- Operating voltage: 230V +/-10% 50Hz.
- Maximum power of 1500W, resistive load.
- Power supply cable: 800mm, 3 Conductors.
- Heating standby mode consumption: <0,5W.
- Electronic PID (Proportional Integral Derivative) control, triggered by a triac (excluding products BXGTHAR2A and BXGTHAR2GA).

Environment:

- IP44 (control panel horizontal oriented after installation).
- Important:** Safety compliance has to be considered for the final product after integration. IP 44 can be met with proper integration. We suggest to have the finished appliance tested by an accredited laboratory to certify the compliance.
- Operating temperature: 0°C to +50°C.
- Storage temperature: -20°C to +70°C.
- Comfort temperature setpoint: between +7°C and +30°C approximately.

- Class II, after installation under the responsibility of the integrator (according to EN60335-1).
- NTC (negative temperature coefficient) electronic temperature sensor.

Packaging:

- Packing unit: box contains fifty items.
- Individual packing: bubblewrap packing bag.

Manufactured by: IMHOTEP création
(contact@imhotepcreation.com)

Applicable directives and standards after integration of the module on the finished appliance (under the responsibility of the integrator):

- LVD 2014/35/UE: EN60335-1 / EN60335-2-30 / EN60335-2-43/ EN62233;
- EMC 2014/30/UE: EN55014-1 / EN55014-2 / EN61000-3-2 / EN61000-3-3;
- ERP 2009/125/CE;
- Regulation 2015/1188/UE ;
- ROHS 2011/65/EU: EN50581

The module is manufactured using processes which are certified ISO 9001 V2015.

PRODUCT CODES

The products described in this instruction booklet are our conventional solutions, which are feasible and available.

Codes	References
BXGTHAR2A	Programmable controller for electric towel rails without infrared receiver, white, CLII with relay
BXGTHAR2GA	Programmable controller for electric towel rails without infrared receiver, grey, CLII with relay
BXGTHART1A	Programmable controller for electric towel rails with infrared receiver, white, CLI with relay + triac
BXGTHART1GA	Programmable controller for electric towel rails with infrared receiver, grey, CLI with relay + triac
BXGTHART2PA	Programmable controller for electric towel rails with infrared receiver, white, CLII with relay + triac, 6-order pilot wire
BXGTHART2PGA	Programmable controller for electric towel rails with infrared receiver, grey, CLII with relay + triac, 6-order pilot wire

We also have a wider range, designed using products developed by us.
Products can be customised (e.g. as regards design, features) upon request.
Please contact us as regards any projects you may have.



IMHOTEP création

ZI Montplaisir - 258 rue du Champ de Courses

38780 Pont-Evêque - France

Tél. : + 33 (0)4 74 58 39 56

Fax : + 33 (0)4 74 58 39 57

E-mail : contact@imhotepcreation.com



www.imhotepcreation.com